

# Motorscope - Uno

**SINGLE PHASE / 0.25kW - 2.2kW / 240V**

TECHNICAL SPECS	
<b>MOTOR VOLTAGE</b>	: 230V AC
<b>CURRENT RANGE</b>	: 1 - 20 Amp Inductive
<b>POWER RANGE</b>	: 0.25 - 2.2kW
<b>FREQUENCY RANGE</b>	: 40 - 70 Hz
<b>CONSUMPTION</b>	: 3VA
<b>RELAY OUTPUT</b>	: 230V - 16A
<b>COS PHI RANGE</b>	: 0 - 1 Inductive
<b>TEMP RANGE</b>	: -15 to +70° C
<b>MECHANICAL</b>	: Weight ±350grams
<b>DIMENSIONS</b>	: 85 x 130 x 50mm

**AUXILIARY INPUT**

**LIQUID LEVEL  
PRESSURE  
TEMPERATURE  
EARTH LEAKAGE**

PROTECTION
* <b>OVER- and UNDER-LOAD</b>
* <b>OVER- and UNDERVOLTAGE</b>
* <b>OVERHEATING (UNCONTROLLED STARTS)</b>
* <b>CAN'T CALIBRATE IN OVERLOAD</b>
* <b>NOT AGAINST LIGHTNING</b>

**GENERAL INFORMATION**

The power used by a working system varies with the application but must stay within safe limits. Power consumption outside of this range indicates a faulty motor or system. The load or power consumption is measured at the input to the motor. When the calibration button is pressed, with the jumper in place, the **MOTORSCOPE** defines the safe range for the system. The motor must, at that time, run under normal working conditions. The power supply has to be correct and stable, this is checked continuously. The **MOTORSCOPE** keeps the motor running as long as the safe limits are not exceeded. The **MOTORSCOPE** has a **RS232** output for serial communication with our **OPTIMIZER** or a **PC**. The **OPTIMIZER** is used to improve settings, as an installation aid and for more detailed fault indication. The **OPTIMIZER** can carry the data of the last 43 motor stops to be transferred to a **PC**.

<b>POSSIBLE ERRORS AT FIRST TIME CALIBRATION</b>				
LED Indication	Reason	Possible cause	Solution	
● LIGHT ON      ○ LIGHT OFF      ✱ LIGHT FLASHING				
<b>NOTE:</b> Start fault finding by checking that all wires and compressed copper connections are properly connected, and that the motor is calibrated at it's normal running condition.				
<b>Red   Yellow   Green</b>				
○   ○   ○	<b>All lights off</b>	Voltage fault	Live and Neutral switched	Switch Live and Neutral wires around.
✱   ✱   ○	<b>Red and Yellow lights flashing</b>	Voltage fault (When the supply voltage recovers and stays within the safe limits for 15 min, normal operation resumes.)	Faulty Earth connection	Check that earth is properly connected. If problem persists, remove the controller's earth wire, connect the motor's earth wire directly to the supply earth wire and then bridge the controller's earth, neutral and COM terminals.
○   ✱   ○	<b>Yellow light flashing</b>	Under-load / Restart timer	Supply voltage incorrect	Phone your power supply company.
●   ✱   ○	<b>Red constant and Yellow flashing</b>	Current fault	Bore-hole dry Broken belt/shaft	Set Restart-timer, for bore-hole to refill. Phone your motor's supplier
○   ●   ●	<b>Green and Yellow constant</b>	No Current	Over current	Current exceeds safe limit.
○   ✱   ✱	<b>Yellow and Green lights flashing</b>	Start delay	Faulty motor cable	Check that the motor cables are properly connected.
●   ○   ○	<b>Red constant</b>	Overload	Too rapid restart	Leave on, unit restarts automatically.
●   ✱   ✱	<b>Red constant, Yellow &amp; Green flashing</b>	Motor can not start	Low voltage at motor Overload	Use a larger diameter cable to motor Check system or contact supplier.
		Wires connected wrongly	Follow <b>"Run, Start and Common wire definition"</b> Check Run and Start Capacitors' connections and size.	

# Installation Instructions

1. Connect the incoming power (**Live, Neutral and Ground**) to the Uno-panel as indicated on the diagram below.  
**Note: If unit is powered from a generator, Ground (⏏) and Neutral MUST be linked.**
2. Connect the outgoing power to the motor as per diagram (Do not forget to earth the motor as indicated).
3. When all connections are properly fastened, proceed with the **First Time Calibration** (See instructions below).

## CONNECTION DIAGRAM FOR 0.25-0.75kW MOTORS

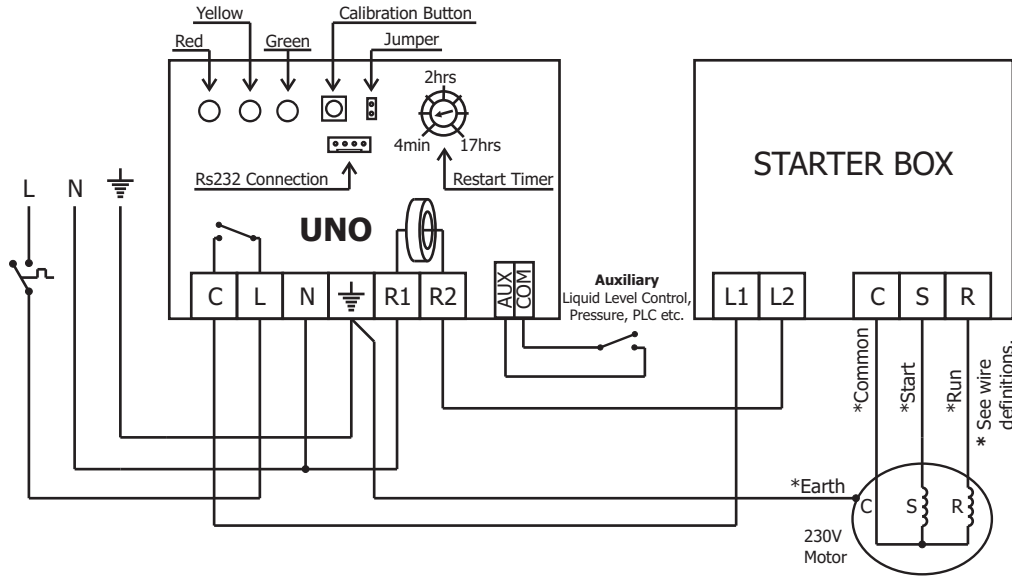

## CONNECTION DIAGRAM WITH CONTACTOR FOR 1.1-2.2kW MOTORS

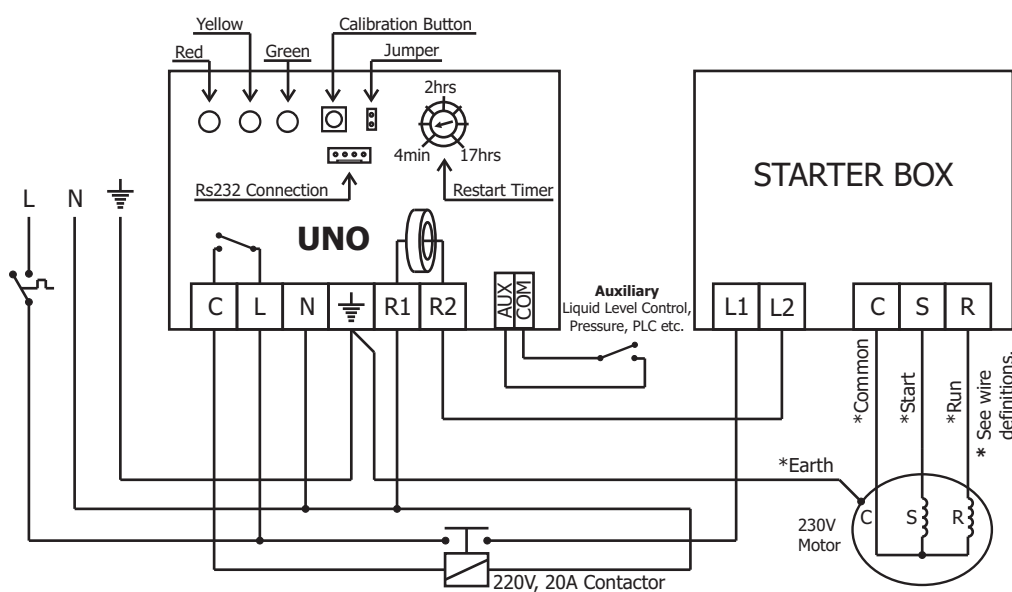

## FIRST TIME CALIBRATION:

(Ensure that all wires and the motor's earth are properly connected before **First Time Calibration**)

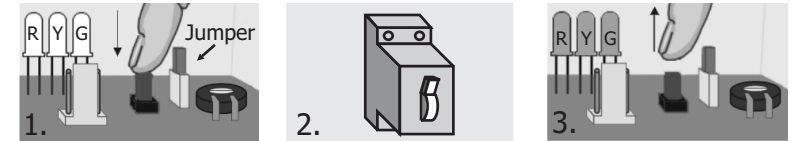

When all the indication lights glow, release the **calibration button** for one second.

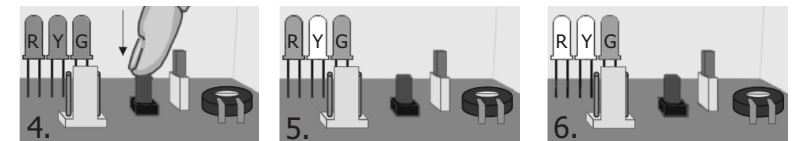

6. The calibration is completed when only the **GREEN** light glows.

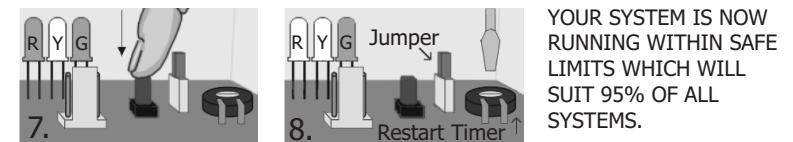

After the pump has run for approximately 5 min; press the **calibration button** again until the **RED** and **GREEN** lights glow, to optimize the automatic calibration.

YOUR SYSTEM IS NOW RUNNING WITHIN SAFE LIMITS WHICH WILL SUIT 95% OF ALL SYSTEMS.

THE OPTIMIZER MAY BE USED TO CUSTOMIZE THE LIMITS TO SUIT YOUR SPECIFIC APPLICATION.

## Run, Start and Common wire definitions:

1. Four wires go down to the motor. Number them **Nº 1, 2, 3** and **4**.
2. Measure resistance from: **1 to 2 =  $\_\_\_\_\_\_ \Omega$ , 1 to 3 =  $\_\_\_\_\_\_ \Omega$ , 1 to 4 =  $\_\_\_\_\_\_ \Omega$ , 2 to 3 =  $\_\_\_\_\_\_ \Omega$ , 2 to 4 =  $\_\_\_\_\_\_ \Omega$ , 3 to 4 =  $\_\_\_\_\_\_ \Omega$ .**
3. The **Earth** wire (**Nº  $\_\_\_\_\_\_$** ) is not connected to any of the motor wires ("O.L." on multi-meter).
4. Highest of the other three measurements is between the **Run** and **Start** windings.
5. The other wire (**Nº  $\_\_\_\_\_\_$** ) is **Common**.
6. **Run** is the wire (**Nº  $\_\_\_\_\_\_$** ) with the lowest resistance from **Common**.
6. **Start** is the wire (**Nº  $\_\_\_\_\_\_$** ) with the highest resistance from **Common**.

**IF ANY ERRORS OCCURRED DURING START-UP, SEE THE REVERSE SIDE FOR POSSIBLE EXPLANATIONS.**