

Motorscope® - Uno Panel

SINGLE PHASE (240V) : 1.1kW / 1.5kW / 2.2kW

Includes capacitors, ON/OFF switch and surge arresters

TECHNICAL SPECS

MOTOR VOLTAGE	: 230V AC
CURRENT RANGE	: 1 - 20 Amp Inductive
POWER RANGE	: 1.1 - 2.2kW
FREQUENCY RANGE	: 40 - 70 Hz
CONSUMPTION	: 3VA
COS PHI RANGE	: 0 - 1 Inductive
TEMP RANGE	: -15 to +70° C
MECHANICAL	: Weight ±1.8kg
DIMENSIONS	: 158 x 238 x 130mm

AUXILIARY INPUT

**LIQUID LEVEL
PRESSURE
TEMPERATURE
EARTH LEAKAGE**

PROTECTION

- * OVER- and UNDER-LOAD
- * OVER- and UNDERVOLTAGE
- * OVERHEATING (UNCONTROLLED STARTS)
- * CAN'T CALIBRATE IN OVERLOAD

GENERAL INFORMATION

The power used by a working system varies with the application but must stay within safe limits. Power consumption outside of this range indicates a faulty motor or system. The load or power consumption is measured at the input to the motor. When the calibration button is pressed, with the jumper in place, the **MOTORSCOPE** defines the safe range for the system. The motor must, at that time, run under normal working conditions. The power supply has to be correct and stable, this is checked continuously. The **MOTORSCOPE** keeps the motor running as long as the safe limits are not exceeded. The **MOTORSCOPE** has a **RS232** output for serial communication with our **OPTIMIZER** or a **PC**. The **OPTIMIZER** is used to improve settings, as an installation aid and for more detailed fault indication. The **OPTIMIZER** can carry the data of the last 43 motor stops to be transferred to a **PC**.

POSSIBLE ERRORS AT FIRST TIME CALIBRATION

● LIGHT ON ○ LIGHT OFF ★ LIGHT FLASHING

NOTE: Start fault finding by checking that all wires and compressed copper connections are properly connected, and that the motor is calibrated at it's normal running condition.

<u>LED Indication</u>	<u>Reason</u>	<u>Possible cause</u>	<u>Solution</u>
Red Yellow Green			
○ ○ ○	All lights off	Voltage fault	Live and Neutral switched
★ ★ ○	Red and Yellow lights flashing	Voltage fault (When the supply voltage recovers and stays within the safe limits for 15 min, normal operation resumes.)	Switch Live and Neutral wires around.
○ ★ ○	Yellow light flashing	Under-load / Restart timer	Faulty Earth connection Supply voltage incorrect
● ★ ○	Red constant and Yellow flashing	Current fault	Phone your power supply company. Set Restart-timer, for bore-hole to refill. Phone your motor's supplier
○ ● ●	Green and Yellow constant	No Current	Over current Current exceeds safe limit.
○ ★ ★	Yellow and Green lights flashing	Start delay	Faulty motor cable Check that the motor cables are properly connected.
● ○ ○	Red constant	Overload	Too rapid restart Leave on, unit restarts automatically.
● ★ ★	Red constant, Yellow & Green flashing	Motor can not start	Low voltage at motor Overload Use a larger diameter cable to motor Check system or contact supplier.
		Wires connected wrongly	Follow "Run, Start and Common wire definition"  Check Run and Start Capacitors' connections and size.

Installation Instructions

1. Connect the incoming power (**Live, Neutral and Ground**) to the Uno-panel as indicated on the diagram below.
Note: If unit is powered from a generator, Ground () and Neutral MUST be linked.
2. Connect the outgoing power to the motor as per diagram (Do not forget to earth the motor as indicated).
3. When all connections are properly fastened, proceed with the **First Time Calibration** (See instructions below).

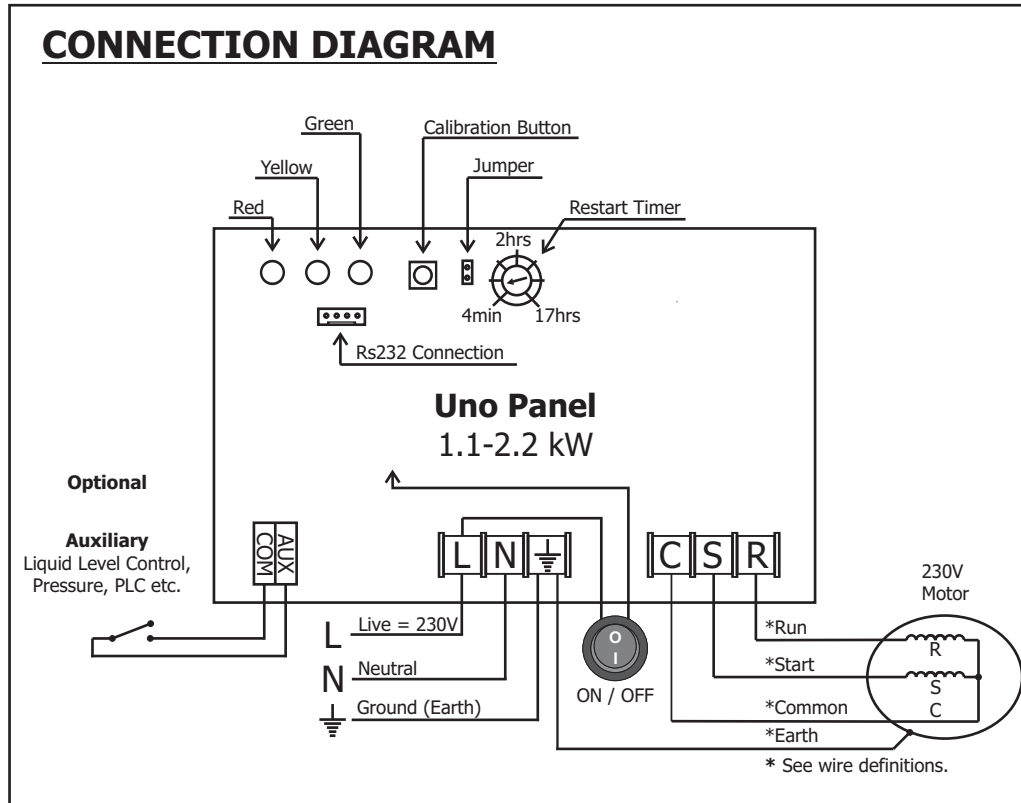

Run, Start and Common wire definitions:

1. Four wires go down to the motor. Number them **Nº 1, 2, 3 and 4**.
2. Measure resistance from: **1 to 2 = $______ \Omega$, 1 to 3 = $______ \Omega$, 1 to 4 = $______ \Omega$, 2 to 3 = $______ \Omega$, 2 to 4 = $______ \Omega$, 3 to 4 = $______ \Omega$.**
3. The **Earth** wire (**Nº**) is not connected to any of the motor wires ("O.L" on multi-meter).
4. Highest of the other three measurements is between the **Run** and **Start** windings.
5. The other wire (**Nº**) is **Common**.
5. **Run** is the wire (**Nº**) with the lowest resistance from **Common**.
6. **Start** is the wire (**Nº**) with the highest resistance from **Common**.

FIRST TIME CALIBRATION:

(Ensure that all wires and the motor's earth are properly connected before **First Time Calibration**)

1. Connect the **jumper** to the two pins as indicated above. Press the **calibration button** while switching the power on at the **ON/OFF** switch on the bottom of the unit.

2. When all the indication lights glow, release the **calibration button** for one second.

3. Press the **calibration button** again until the motor starts (± 3 sec). The calibration will start automatically.

4. First the **RED** and **GREEN** light will glow for 4 seconds, indicating that calibration is in progress.

5. The calibration is completed when only the **GREEN** light glows.

6. YOUR SYSTEM IS NOW RUNNING WITHIN SAFE LIMITS WHICH WILL SUIT 95% OF ALL SYSTEMS.

7. After the pump has run for approximately 5 min; press the **calibration button** again until the **RED** and **GREEN** lights glow, to optimize the automatic calibration.

8. Calibration is finished when only the **GREEN** light glows. Place the **jumper** on one pin to keep the set limits and to prevent tampering. Adjust the **Restart Timer** (with a screwdriver) to set the dry-run recovery time.

THE OPTIMIZER MAY BE USED TO CUSTOMIZE THE LIMITS TO SUIT YOUR SPECIFIC APPLICATION.

TO START OR STOP, USE THE ON/OFF SWITCH AT THE BOTTOM OF THE ENCLOSURE.

IF ANY ERRORS OCCURRED DURING START-UP, SEE THE REVERSE SIDE FOR POSSIBLE EXPLANATIONS.